

Backless Bench

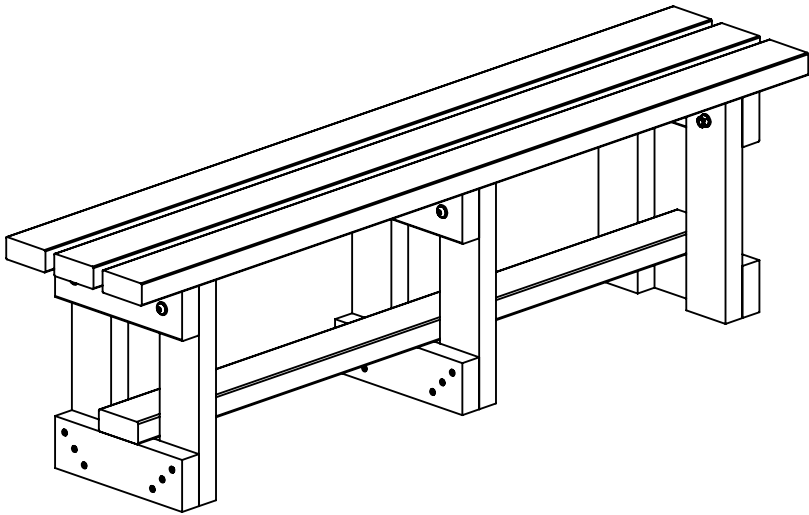

Assembly Guide

NBB
Recycled
Furniture

NBB
Outdoor
Shelters

NBB
Premises
& Matting

NBB
School
Shelters

Notes:

Parts and Fittings

One Person required
for safe assembly

Bench Seat



Ground support beam



Leg assembly



Fittings

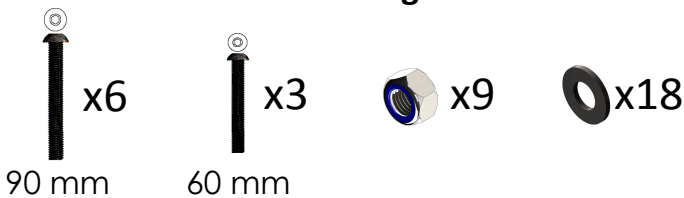

Tools supplied



17mm Spanner x1

6mm Allen Key x1

Step 1

Place bench seat on a soft surface with support slats facing upwards.

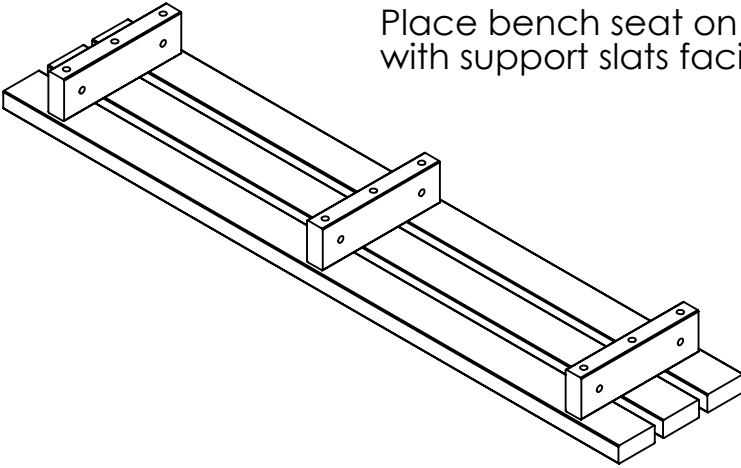

Step 2



x4



x8



x4

Place the legs with the supports facing outwards and use Spanner and Allen Key to tighten the bolt together.

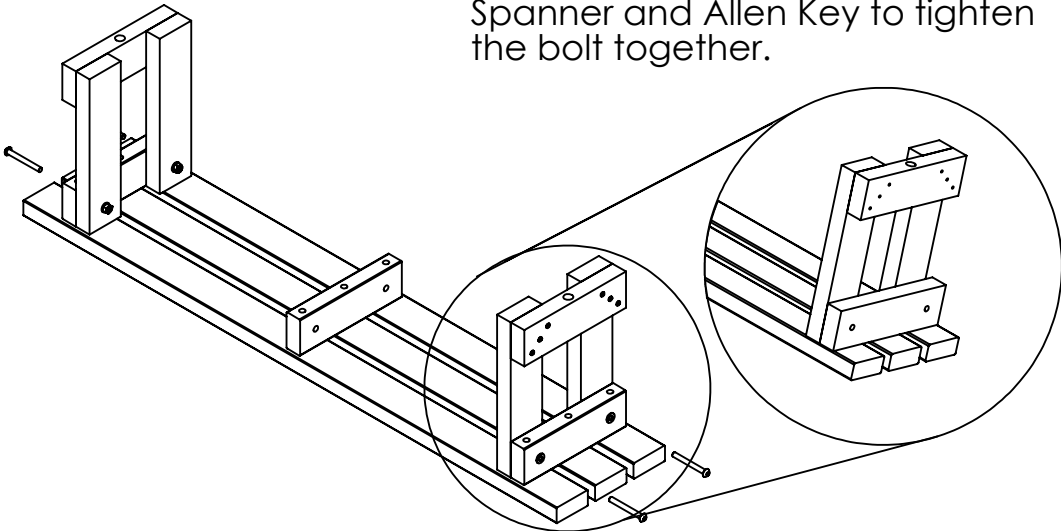

Step 3

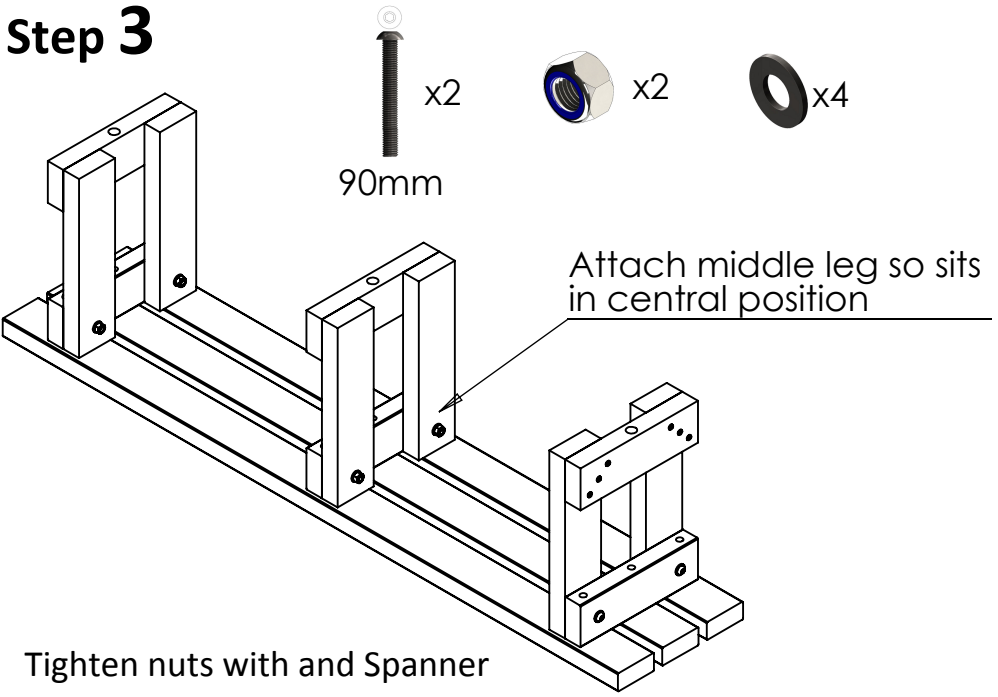

Step 4

hold the support bar underneath the legs and use the Allen key to fix the bolts into position

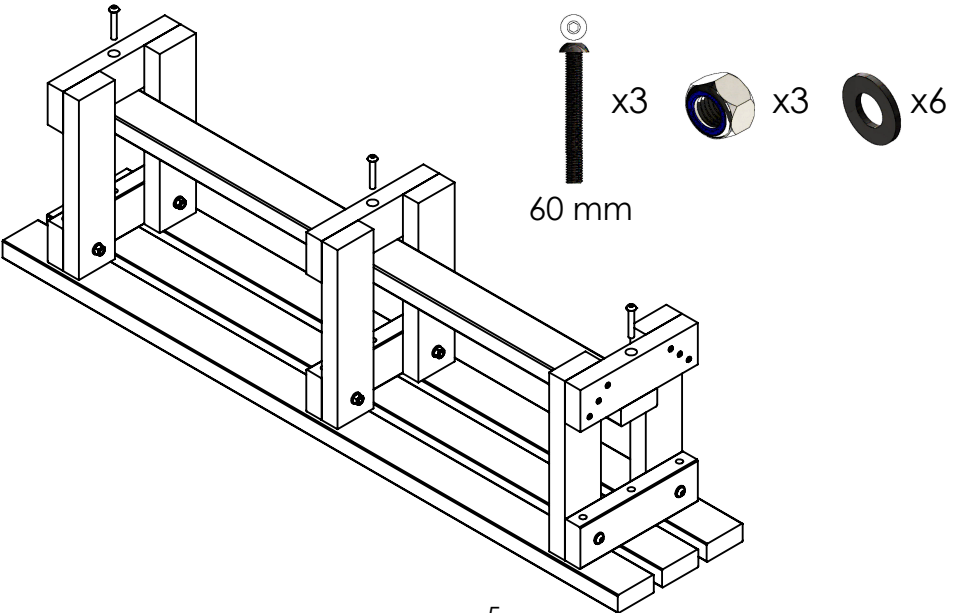

Notes:

Notes:

THANK YOU FOR PURCHASING THIS PRODUCT

CONTACT DETAILS:

Email : sales@recycledfurniture.co.uk

Web : www.recycledfurniture.co.uk

Tel : 0800 1777 052

NBB Recycled Furniture, Unit 5, 145 Sterte Road, Poole, Dorset BH15 2AF

All Parts and Fixings checked by:	
Print Name:	Signature